



SHEPPARD

A Bendix CVS Company • A member of Knorr-Bremse

Operator's Manual

Sheppard® Active Steering System
by Bendix CVS



Bendix safety technologies complement safe driving practices. No commercial vehicle safety technology replaces a skilled, alert driver exercising safe driving techniques and proactive, comprehensive driver training. Responsibility for the safe operation of the vehicle remains with the driver at all times.

**DO NOT
REMOVE FROM
VEHICLE**

This booklet contains important operational and safety information that benefits you and subsequent drivers.

Important Safety Information About The Sheppard® Active Steering System by Bendix CVS

GENERAL SAFETY GUIDELINES



WARNING! PLEASE READ AND FOLLOW THESE INSTRUCTIONS!



TO AVOID PERSONAL INJURY OR DEATH:

When working on or around a vehicle, the following guidelines should be observed **AT ALL TIMES**:

- ▲ Park the vehicle on a level surface, apply the parking brakes and always block the wheels. Always wear personal protection equipment.
- ▲ Stop the engine and remove the ignition key when working under or around the vehicle. When working in the engine compartment, the engine should be shut off and the ignition key should be removed. Where circumstances require that the engine be in operation, **EXTREME CAUTION** should be used to prevent personal injury resulting from contact with moving, rotating, leaking, heated or electrically-charged components.
- ▲ Do not attempt to install, remove, disassemble or assemble a component until you have read, and thoroughly understand, the recommended procedures. Use only the proper tools and observe all precautions pertaining to use of those tools.
- ▲ If the work is being performed on the vehicle's air brake system, or any auxiliary pressurized air systems, make certain to drain the air pressure from all reservoirs before beginning **ANY** work on the vehicle. If the vehicle is equipped with a Bendix® AD-IS® air dryer system, a Bendix® DRM™ dryer reservoir module, a Bendix® AD-9si, AD-HF®, or AD-HF^{®i} air dryer, be sure to drain the purge reservoir.
- ▲ Following the vehicle manufacturer's recommended procedures, deactivate the electrical system in a manner that safely removes all electrical power from the vehicle.
- ▲ Never exceed manufacturer's recommended pressures.
- ▲ You should consult the vehicle manufacturer's operating and service manuals, and any related literature, in conjunction with the Guidelines above.
- ▲ Never connect or disconnect a hose or line containing pressure; it may whip and/or cause hazardous airborne dust and dirt particles. Wear eye protection. Slowly open connections with care, and verify that no pressure is present. Never remove a component or plug unless you are certain all system pressure has been depleted.
- ▲ Use only genuine Bendix® brand replacement parts, components and kits. Replacement hardware, tubing, hose, fittings, wiring, etc. must be of equivalent size, type and strength as original equipment and be designed specifically for such applications and systems.
- ▲ Components with stripped threads or damaged parts should be replaced rather than repaired. Do not attempt repairs requiring machining or welding unless specifically stated and approved by the vehicle and component manufacturer.
- ▲ Prior to returning the vehicle to service, make certain all components and systems are restored to their proper operating condition.
- ▲ For vehicles with Automatic Traction Control (ATC), the ATC function must be disabled (ATC indicator lamp should be ON) prior to performing any vehicle maintenance where one or more wheels on a drive axle are lifted off the ground and moving.
- ▲ The power **MUST** be temporarily disconnected from the radar sensor whenever any tests **USING A DYNAMOMETER** are conducted on a vehicle equipped with a Bendix® Wingman® system.

 **WARNING**

Improper use of the Sheppard® Active Steering Assist System by Bendix CVS can result in a collision resulting in property damage, serious injuries, or death. Be sure to read, understand, and carefully follow the instructions this document.

 **WARNING**

Due to the inherent limitations of image recognition technology, camera-based safety technology — on rare occasions — may not be able to detect or may misinterpret lane markings. At these times, alerts may not occur, or erroneous alerts may occur.

 **WARNING**

Bendix safety technologies complement safe driving practices. No commercial vehicle safety technology replaces a skilled, alert driver exercising safe driving techniques and proactive, comprehensive driver training. Responsibility for the safe operation of the vehicle remains with the driver at all times.

 **WARNING**

This product may expose you to chemicals including Nickel, which is known to the State of California to cause cancer and birth defects or other reproductive harm. For more information, go to P65Warnings.ca.gov.

IMPORTANT: It is the responsibility of the driver to remain vigilant and change driving practices depending on traffic and road conditions.

 **IMPORTANT**

All vehicle Diagnostic Trouble Codes (DTCs) related to the engine, transmission, instrument cluster, engine cruise control, and Bendix® ABS, ATC, or ESP® systems must first be resolved, with no DTCs present during the vehicle operation while in cruise control, prior to running Bendix® ACom® Pro diagnostics to resolve Sheppard® Active Steering System by Bendix CVS DTCs faults.

 **IMPORTANT**

System Problems. If a problem with the Sheppard® Active Steering System by Bendix CVS is detected, it should be serviced as soon as possible to restore full functionality. The vehicle does not need to be taken out of service, the Lane Keep Assist (LKA) will be deactivated.

The Sheppard® Active Steering System by Bendix CVS

The Sheppard® Active Steering System by Bendix CVS is a driver assistance system, helping the driver with a suite of steering assist features and driver assist steering features integrated with the Bendix® FLC-20™ camera, Bendix® Wingman® Fusion™ or a compatible third party camera. The active steering system does not replace the driver or driving skills.

The driver is solely responsible for maintaining control of the vehicle with both hands on the steering wheel. The active steering system combines unique active steering technology with a forward-facing camera for active lane correction. This system helps mitigate potential side collisions and lane-departure related accidents, as well as increase driver comfort.

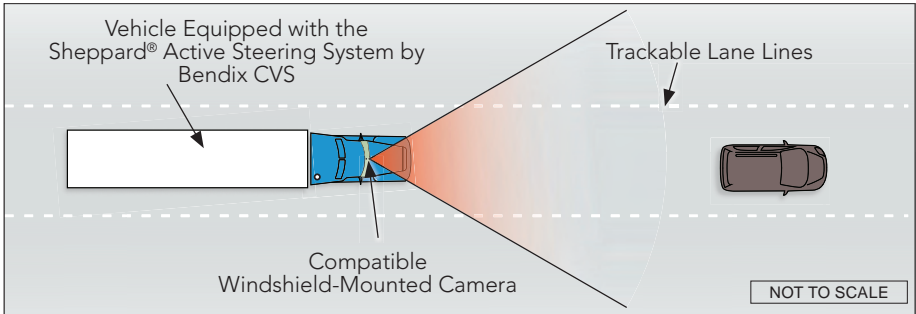

The Sheppard® Active Steering System by Bendix CVS

What Features are Included in the Sheppard® Active Steering System by Bendix CVS?

Lane Keep Assist (LKA)

- Detects lane markings and evaluates relative vehicle position
- Recognizes when the vehicle begins to drift towards the lane markings
- Distinguishes between planned lane changes and lane drifting
- Intervenes before the vehicle reaches the lane markings
- Automatically applies a correction torque to the steering wheel
- Smoothly releases steering torque as soon as the vehicle trajectory is re-established
- The system enables the driver to suppress or override steering torque
- LKA is activated at 37 mph/60 kph

Steering Assist

- Speed Dependent Steering Assist - Provides variable steering assist based on vehicle speed. It helps the driver experience easier steering at low speeds and a firmer steering response at higher speeds. It also aids the driver by reducing fatigue and helps the driver maintain better control of the vehicle.
- Active Return - Helps to reduce driver fatigue through easier maneuvering by returning the steering wheel to the center position at lower vehicle speeds.
- Crown/Side-Wind Compensation - Helps to reduce driver fatigue, or steering effort, by helping keep the vehicle straight during heavy side winds, crowned roads, or some alignment issues.
- Road Disturbance Compensation - Helps improve driver comfort by reducing steering wheel vibration typically caused by road disturbances like potholes, road debris, or other bumps in the road.

System Components

Bendix® AutoVue® FLC-20™ Camera

- The forward-facing camera tracks the lane markers and provides the lane characteristics for the left and right marker to the Sheppard® Active Steering System by Bendix CVS system over the vehicle communication network. In addition, the system also provides information on when the lane departure warnings will be suppressed, allowing the LKA feature to be suppressed at the same time.
- For additional information, see the *Bendix® AutoVue® FLC-20™ Camera Service Data sheet SD-64-20124* available for download on bendix.com.
- Is compatible with later versions of Bendix Wingman Fusion systems.

LDW Windshield Mounting Bracket

- The bracket that holds the camera secure and keeps it facing the correct direction to successfully determine lane width and position.

Active Steering ECU

- The Electronic Control Unit (ECU) for the Sheppard Active Steering System by Bendix CVS is a standalone unit designed to work with J1939 Vehicle CAN and a forward-facing lane sensing camera.

Magnetic Torque Overlay Power Steering Gear

- Perform a visual inspection to ensure proper installation and functionality. The power steering gear with magnetic torque overlay should be clean and free of fluid. All connectors around the gear should be connected and secured.
- For additional service and troubleshooting information see the *Sheppard® D-Series Integral Power Steering Gear manual* available online from the Customer Service tab on RHSheppard.com.

System Components

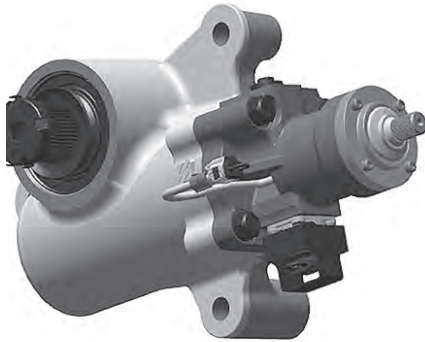

Magnetic Torque Overlay
Steering Gear

Bendix® AutoVue® FLC-20™
Camera with Bracket



Active Steering
Electronic Control
Unit (ECU)

Starting Bendix® ACom® PRO Diagnostic Software

The Bendix® ACom® PRO Diagnostics Software can be started from the desktop shortcut, or from the main Windows® screen with “Start...Programs...Bendix...ACom PRO Diagnostics Software”. To begin, the technician selects “Connect” from the upper panel.



Starting Bendix® ACom® PRO Diagnostic Software

NOTE: When using ACom PRO Diagnostic Software for the first time, the service technician will need to check the communication adapter for the Sheppard Active Steering System by Bendix CVS controller. The technician will need to indicate which communication protocol to use with “Application Settings...Preferences...Connection”. Once a successful connection has been made, these steps will no longer be necessary.

The Bendix ACom PRO Diagnostic Software for Active Steering System User Guide is available in the software download and should be used as a reference to all functions of the ACom PRO service tool.

Additional support at bendix.com / 1-800-AIR-BRAKE (1-800-247-2725), option 2

For the latest information, and for downloads of the Bendix® ACom® PRO Diagnostics software, and its User Guide, visit the Bendix website at: bendix.com.

For direct telephone technical support, the Bendix Tech Team is available at 1-800-AIR-BRAKE (1-800-247-2725), option 2. Follow the instructions in the recorded message. Representatives are available to assist you Monday - Thursday, 8 a.m. - 6 p.m. ET and Friday, 8 a.m. - 5 p.m. ET.

The Bendix Tech Team can also be reached by email at: techteam@bendix.com.

R.H. SHEPPARD TECHNICAL SUPPORT 1-800-274-7437

The Sheppard hours are: Representatives are available Monday – Friday, 7 a.m. - 6 p.m. ET. Representatives can also be reached at: serviceweb@rh-sheppard.com.

Additional Reference Information

- For installation of the Bendix® AutoVue® FLC-20™ camera see *Bendix Service Data sheet SD-64-20124*, available on Bendix.com.
- For installation of the steering gear see the *Sheppard® D-Series Integral Power Steering Gear manual*, available on RHSheppard.com.
- For installation of the ECU see the OEM service information.

The trademarks used in this document, including Bendix®, are United States trademarks owned by or licensed to Bendix Commercial Vehicle Systems LLC.



SHEPPARD

A Bendix CVS Company • A member of Knorr-Bremse

Log-on and Learn from the Best

On-line training that's available when you are —24/7/365.
Visit brake-school.com.

