



SHEPPARD

Quality Engineered Products. Unlimited Capabilities.

SLAVE GEAR HOSE ROUTING FOR NON-COOLING SLAVE

The cooling slave design has been in use for many years. Steering system fluid was routed from the master gear through a port running the length of the slave gear, then back to the reservoir. It was designed to help remove heat from the steering system. From 2007-on, the slave gear cooling ports have been removed and return line fluid is routed directly from the outlet port of the master gear, back to the reservoir.

On vehicles where a cooling slave is being replaced with a non-cooling slave; the 2 large lines which connected to each end of the cooling port on the slave gear can be eliminated. One of the lines can be shortened to run from the outlet port of the master gear back to the reservoir, or a new line may be installed.



M90SAD1 Rev J and earlier

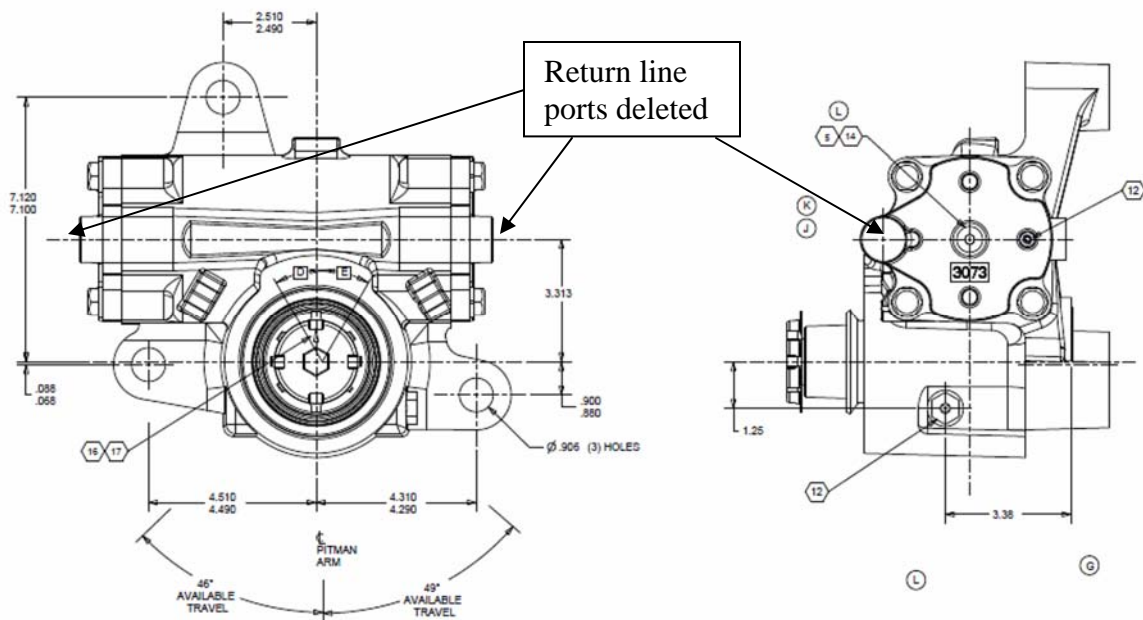

M90SAD1 Rev K and later

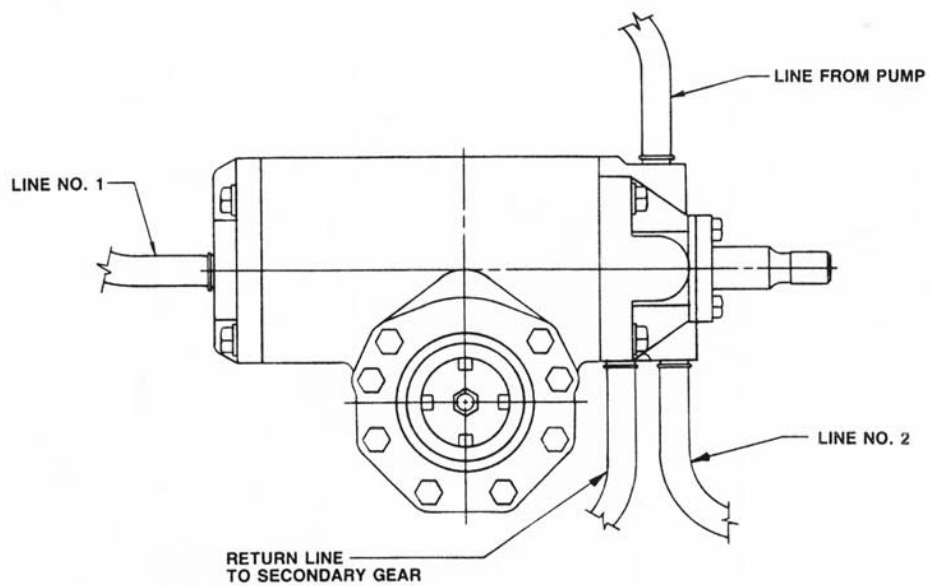
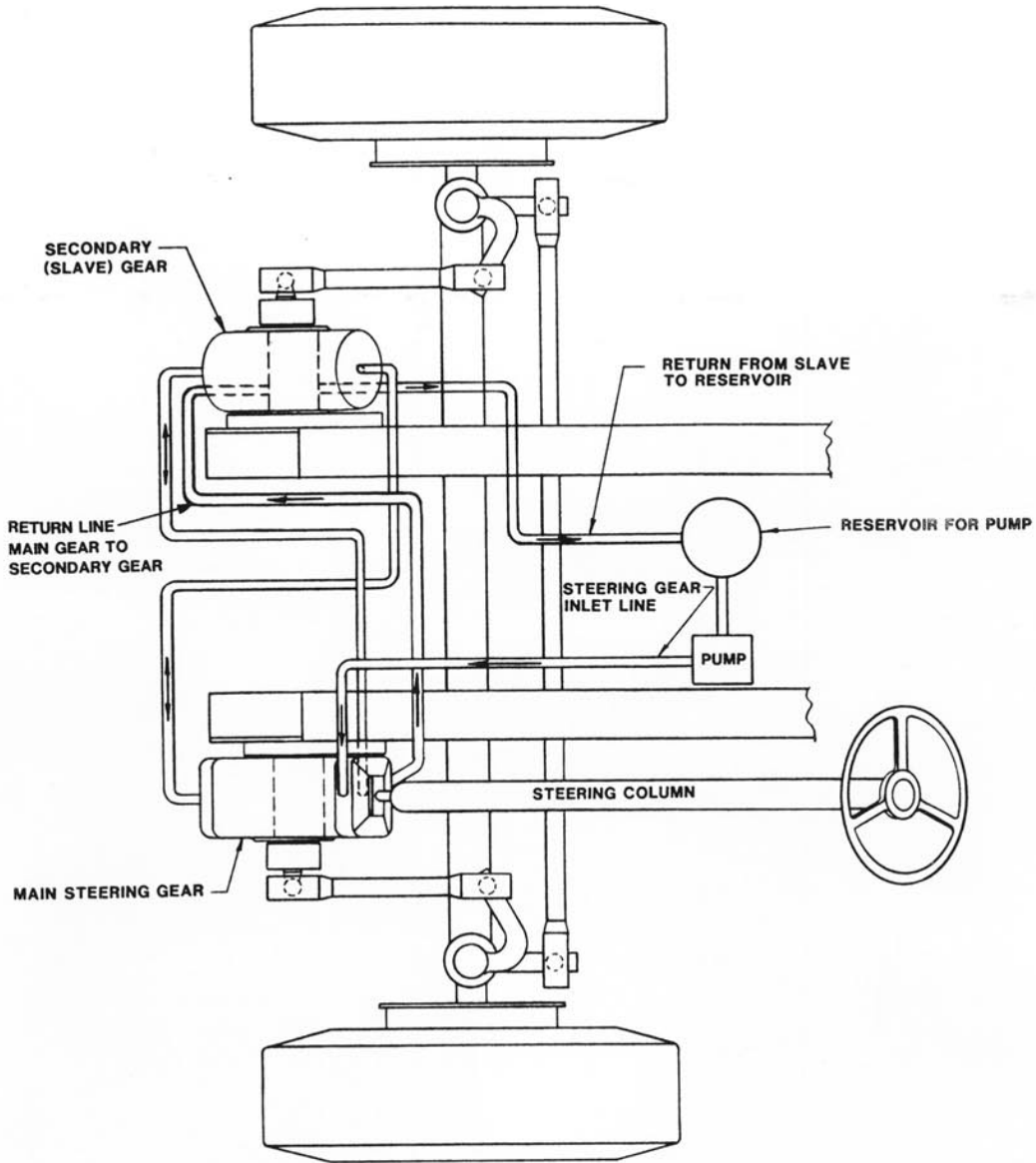
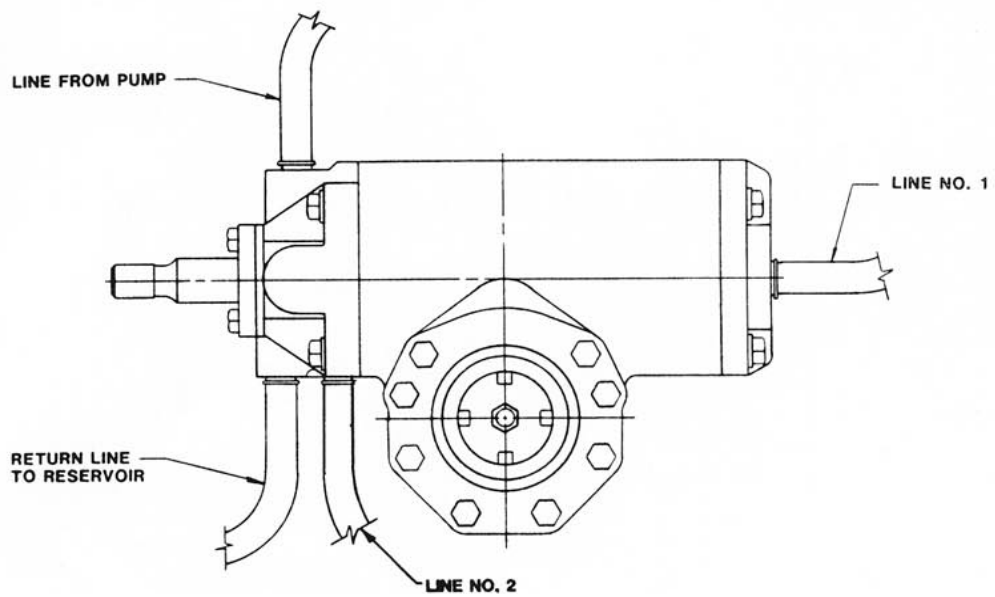
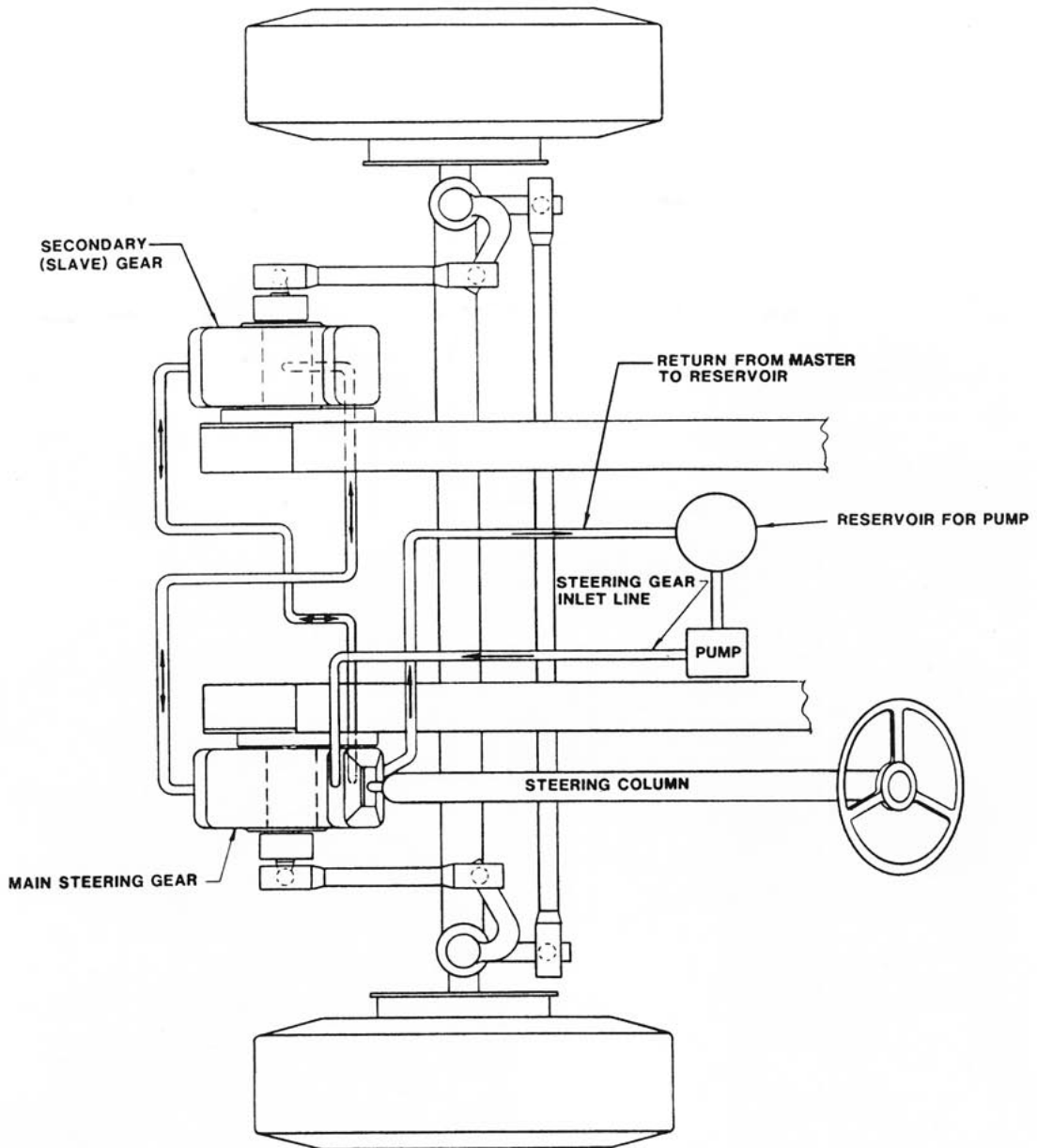

Figure 150

HOSE ROUTING WITH COOLING SLAVE



re 149

HOSE ROUTING WITHOUT COOLING SLAVE